

# PRÉSENTOIRS | Comptoirs d'exposition

# WFH 150

VITRINES RÉFRIGÉRÉES VERTICALES ▶ COMPTOIR DE SERVICE ASSISTÉ



▶ STATIQUE

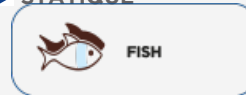

## DÉTAILS



Dessus de granit de Couleur BLANC



Cuve d'exposition en acier inoxydable AISI 316



Structure incurvée de la calotte en verre trempé

## CARACTÉRISTIQUES GÉNÉRALES

- Comptoir réfrigéré pour le service assisté
- Idéal pour l'exposition et la vente de poissons
- Dessus de travail en granit
- Zone d'affichage en acier inoxydable AISI 316
- Refroidissement statique
- Évaporateur traité anti-corrosion
- Structure incurvée de la calotte en verre trempé
- Cuve isolé en mousse d'eau
- Pieds réglables N° 4
- Classe énergétique: G

## SPÉCIFICATIONS TECHNIQUES

Capacité	305 L
Température	M1 (-1°C-+5°C)
Consommation	8 kWh/24h
Puissance nominale	373 W
Niveau de bruit	63 dB(A)
Poids net	178 Kg
Poids brut	225 Kg
Dimensions extérieures (LxPxH mm)	1500x1200x1180
Dimensions internes (LxPxH mm)	1400x860x260
Dimensions de l'emballage (LxPxH mm)	1600x1270x1130
Quantités de chargement 20'/40'/40'HQ	8/18/18

## DIMENSIONS DU PRODUIT

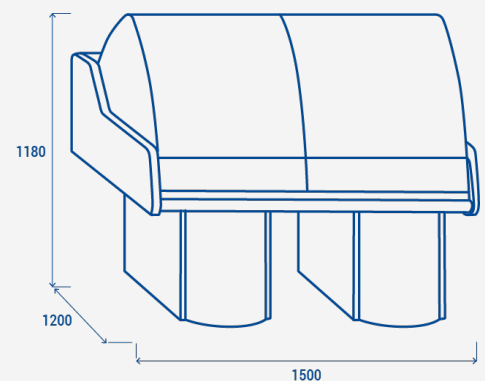

## CERTIFICATIONS

